



P K PUMPS PVT.LTD.

AN ISO 9001-2008 COMPANY



SOLID HANDLING MUD PUMP-TYPE PKs

CE

www.pkpump.in



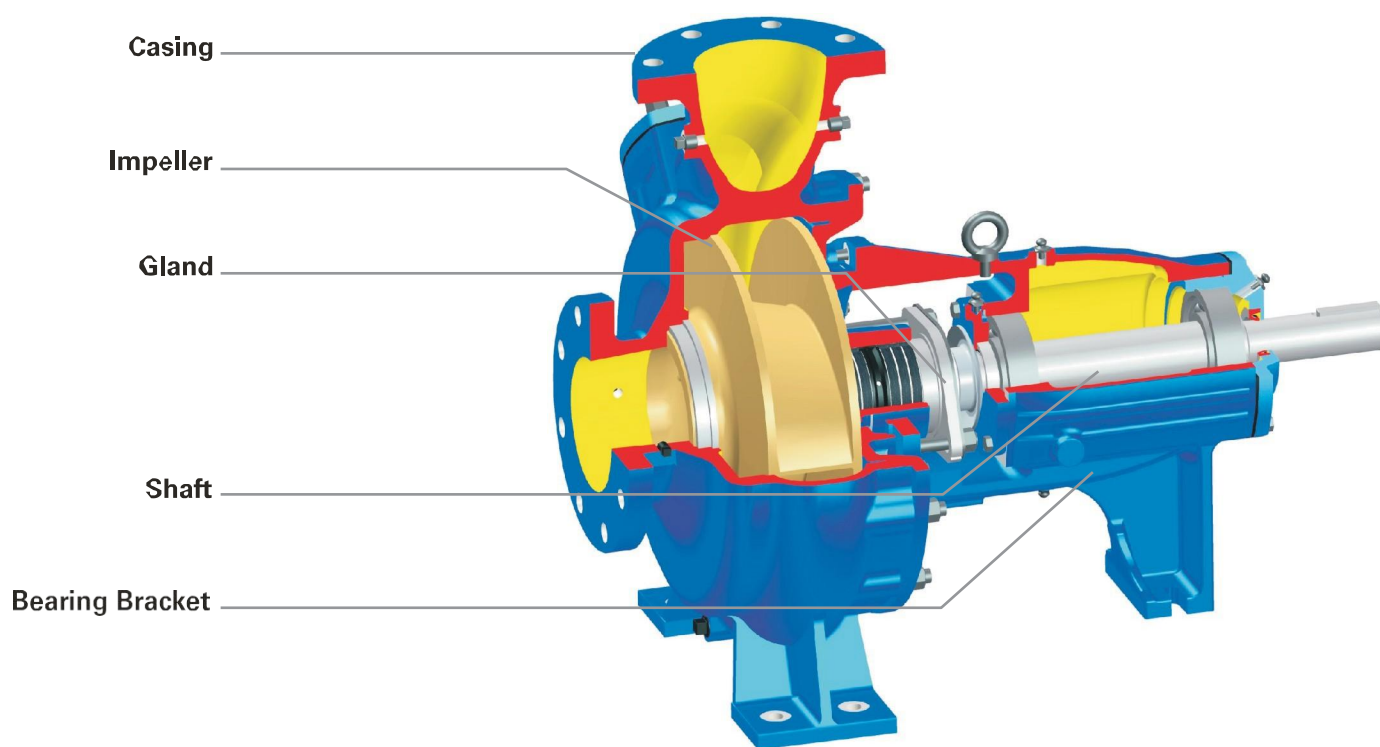

RANGE

Delivery size up to 200 mm

Capacity up to 800 m³/hr

Head up to 90 m

Max. permissible solid size up to 105 mm,
depending on the model consistency up to 5%

QP impellers for more than 6% consistency

Q impellers for more than 4% consistency

APPLICATIONS

For handling liquids with solids in suspension, sludge or pulpy material in Paper Industries, sewage or waste with soft solids in suspension, viscous liquids or liquids carrying fibrous material or powdered material slurries, contaminated process liquids like Sugar factory waste, trade liquors, Water Carrying Gravel, etc.



P K PUMPS PVT.LTD.

AN ISO 9001-2008 COMPANY

CONSTRUCTIONAL FEATURES

Pump Casing :

End suction with top centreline delivery as well as horizontal side delivery. High efficiency volute providing smooth unobstructed flow. Delivery flange and feet are cast integral with the casing. A large inspection opening is provided on casing with easily removable cover.

Impeller :

Single suction type non-clog, free flow impeller dynamically balanced. Enclosed or semi-open impellers are available in code N, P, Q or R.

Shafts :

In SHM pumps, four driving units cover the entire range. Shaft is supported by two bearings. Shaft in stuffing box area is protected by a shaft sleeve. Axial clearance between semi-open impeller and suction wear plate can be adjusted externally without dismantling the pump. The shaft sleeves under bearing housing and bearing spider are shrunk fitted to shaft in SHS pumps.

Stuffing Box :

Standard stuffing box is gland packed with grease sealing. Without cooling up to 90°C and with cooling up to 140°C. Mechanical seal option is also available.

Bearings :

SHM Pumps

Standard : Deep groove ball bearings at DE/NDE.

Optional : Deep groove ball bearing at DE and roller bearing at NDE.

A pair of angular contact ball bearings at DE and one cylindrical roller bearing at NDE.

Standard lubrication is grease and optional is oil.

SHS Pumps

Intermediate shaft bearing is rubber (For water Lubrication) and bronze bearing (For grease lubrication). Thrust ball bearing in combination with metallic journal bearing at head shaft. Transmission bearings are lubricated with external clear water or grease.

Thrust bearings are grease lubricated.

Direction Of Rotation :

Clockwise viewed from driving end.

Drive :

These pumps are suitable for coupling with electric motor or engine directly or through belt drives.

Flanges :

Standard : drilling to DIN 2533 ND 16

Optional : drilling to ASA/BS/IS



P K PUMPS PVT.LTD.

AN ISO 9001-2008 COMPANY

GENERAL DIMENSIONS / MOUNTING DETAILS

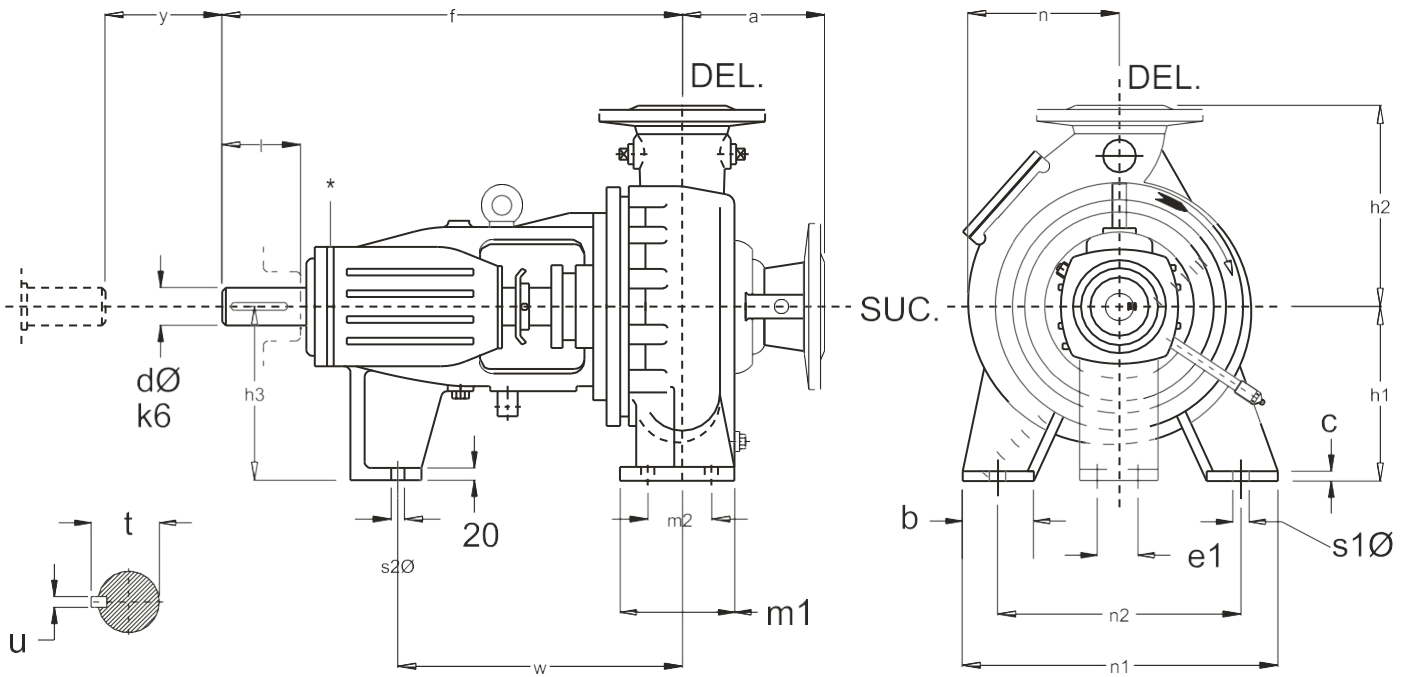

Shaft End

View from Driving End

DIMENSIONS

Pump	Driving Unit	SUC Ø	DEL Ø	Pump Dimension				Foot Dimensions							Shaft End					Wt. Kg.										
				a	f	h1	h2	n	b	c	m1	m2	n1	n2	s1	s2	e1	w	h3	dØ	l	t	u	y						
PKS 50/26	SHM 7	65	50	150		200	250	180	65		135	95	320	250	14				200							100				
PKS 50/26 NB					570	225	280	210		18						15	110	400		32	80	35	10	140		126				
PKS 65/32 NB		80	65	180						80		160	120	400	315	18				225							120			
PKS 80/26		100	80			200	250	195											200							120				
PKS 100/26						225	280	217																		140				
PKS 100/32	SHM 9	125	100			180	630	250	315	237	80	18	160		80		400	315		18	15	110	400	225	42	80	45	12	140	165
PKS 80/40		100	80																	225							168			
PKS 150/26 NB		150	150	200	640	280	355	270	100					90													140			
PKS 100/40		125	100	180																							200			
PKS 150/26	SHM 11					280	355	270																			170			
PKS 150/32		150	150		710				100		160	90	450	355	18	15	110	450	280	50	110	55.5	14	180		210				
PKS 150/40		200	200	200		315	400	296																			230			
PKS 200/32								329		20																	300			
PKS 150/50	SHM 13	150	150			330	450	343					560	460													325			
PKS 200/40		200	200	225	885	320	400	302		120	20	200	130	500	400	18	15	110	650	330	60	110	63.5	18	180		350			

NOTE:

- 1) All dimensions are in mm
- 2) Dimensions for oil and grease lubricated pumps are common.

CROSS SECTIONAL VIEW

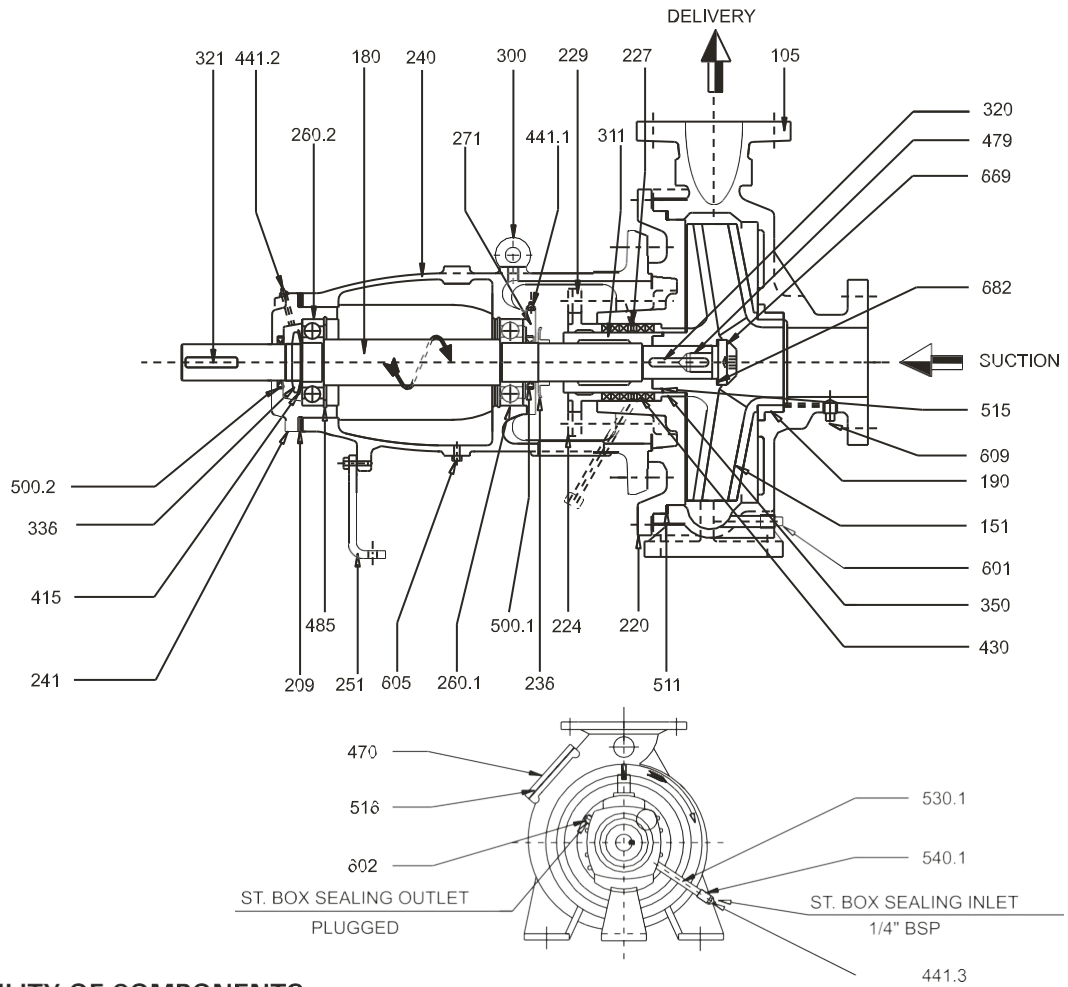

INTERCHANGEABILITY OF COMPONENTS

Part No.	Name of the Part	Total no. of Parts	50/26	50/26B	80/26	65/32	65/32B	100/26	100/32	80/40	150/26B	150/26	150/32	200/32	100/40	150/40	200/40	150/50
			SHM-7			SHM-9			SHM-11			SHM-13						
10500	Pump Casing	13	1	1	2	3	3	4	5	6	7	7	8	9	10	11	12	13
15100	Impeller	16	1	2	3	4	5	6	7	8	9	10	11	12	13	14	15	16
18000	Shaft	4	1	1	1	1	1	2	2	2	2	3	3	3	3	3	4	4
19000	Casing Ring	8	1	1	2	3	3	4	4	2	5	5	5	6	4	5	7	8
22000	Casing Cover	10	1	1	1	2	2	3	4	5	3	6	7	7	8	8	9	10
22700	Lantern Ring	4	1	1	1	1	1	2	2	2	2	3	3	3	3	3	4	4
22900	Gland	4	1	1	1	1	1	2	2	2	2	3	3	3	3	3	4	4
23600	Deflector	4	1	1	1	1	1	2	2	2	2	3	3	3	3	3	4	4
24000	Bearing Housing	4	1	1	1	1	1	2	2	2	2	3	3	3	3	3	4	4
24100	Cartridge	4	1	1	1	1	1	2	2	2	2	3	3	3	3	3	4	4
25100	Support Foot	2	1	1	1	2	2	-	-	-	-	-	-	-	-	-	-	-
26001	Bearing NDE	4	1	1	1	1	1	2	2	2	2	3	3	3	3	3	4	4
26002	Bearing DE	4	1	1	1	1	1	2	2	2	2	3	3	3	3	3	4	4
27100	Bearing Cover	4	1	1	1	1	1	2	2	2	2	3	3	3	3	3	4	4
31100	Shaft Sleeve	4	1	1	1	1	1	2	2	2	2	3	3	3	3	3	4	4
32000	Impeller Key	4	1	1	1	1	1	2	2	2	2	3	3	3	3	3	4	4
32100	Coupling Key	4	1	1	1	1	1	2	2	2	2	3	3	3	3	3	4	4
35000	Stuffing Box Bush	4	1	1	1	1	1	2	2	2	2	3	3	3	3	3	4	4
47000	Inspection Hole Cover	3	1	1	1	1	1	2	2	1	3	3	3	3	2	3	3	3

DIFFERENT TYPES OF IMPELLER FOR SOLID HANDLING PUMP TYPE 'SHM'

N- TWO VANES ENCLOSED IMPELLER

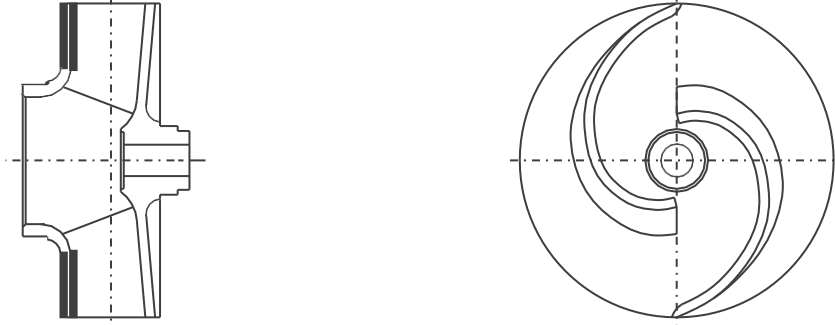

P- SINGLE VANE ENCLOSED IMPELLER

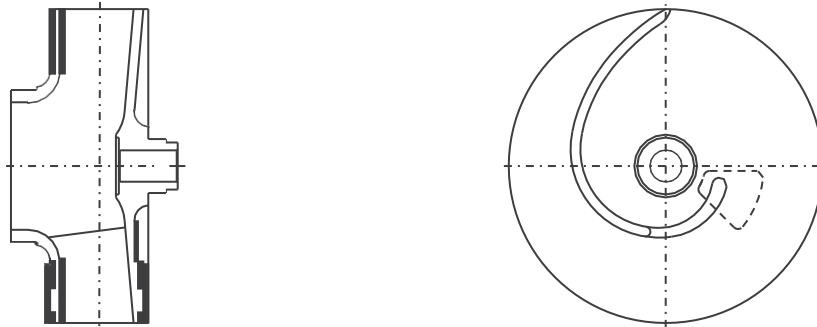

Q/QP - THREE VANES SEMIOPEN IMPELLER

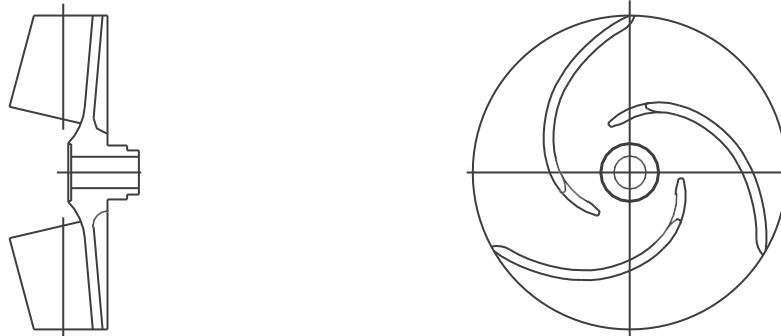

R - EIGHT VANES FREE FLOW IMPELLER

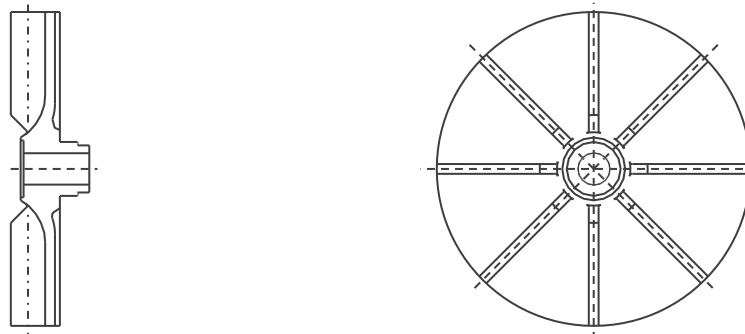

STUFFING BOX COOLING ARRANGEMENT

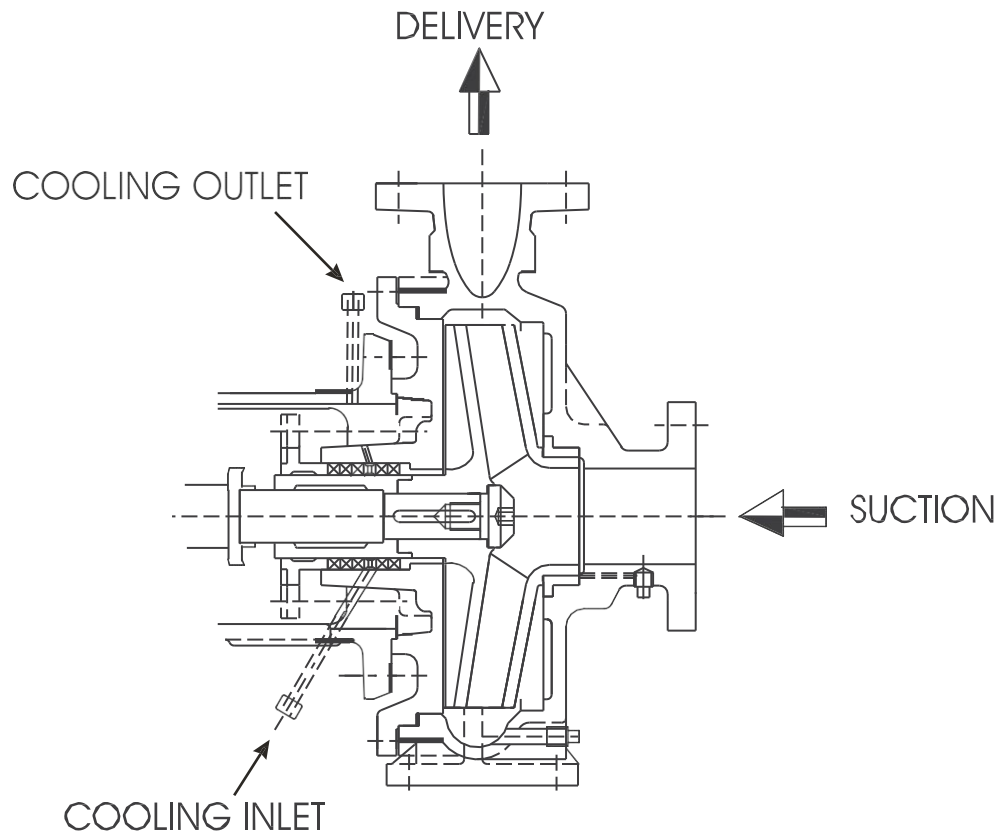

GENERAL DIMENSIONS / MOUNTING DETAILS

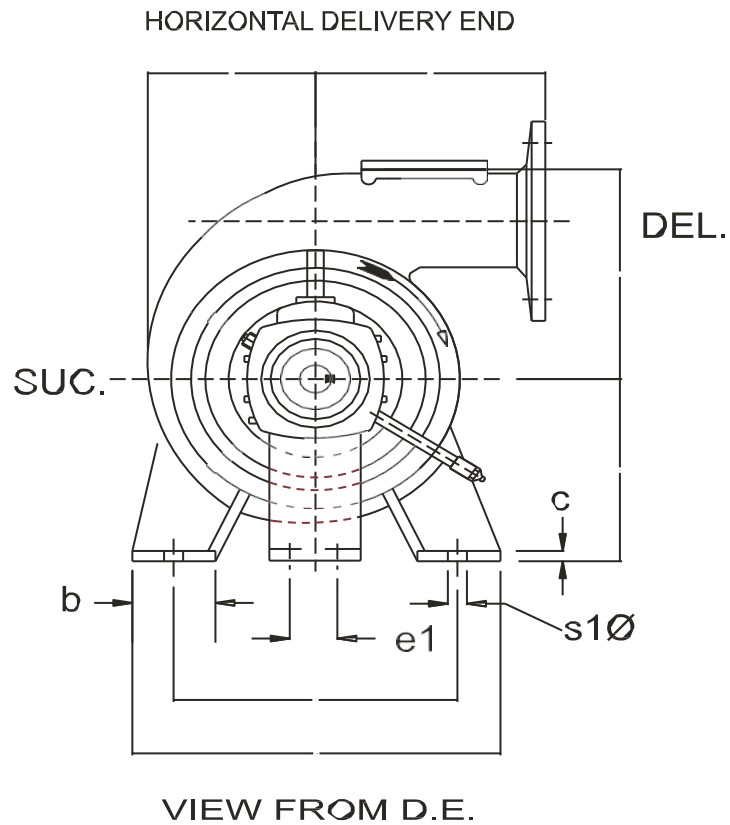

MATERIAL OF CONSTRUCTION

Casing	Cast Iron / Cast Steel / Stainless Steel / Duplex Steel
Casing Cover	Cast Iron / Cast Steel / Stainless Steel
Impeller	Cast Iron / Bronze / Phosphor Bronze / Cast Steel / Stainless Steel / Chrome Steel / Duplex Steel
Wear Ring	Cast Iron / Bronze / Stainless Steel
Shaft	Carbon Steel / Stainless Steel / Duplex Steel
Shaft Sleeve	Stainless Steel / Bronze / Chrome Steel
Lantern Ring	Cast Iron / Bronze / Stainless Steel
Gland	Cast Iron / Bronze

MATERIAL STANDARDS - GENERAL INFORMATION

Material Type	Indian Standard (IS)	American standard (ASTM)	DIN
Cast Iron			
Cast Iron	IS 210 Gr. FG 260	ASTM A48 Class 40	(0.6025)DIN 1691 GG25
Spheroidal Graphite Cast Iron			
SG Iron (Ductile Iron)	IS 1865 Gr 400/15	A536, 60-40-18	(0.7040)DIN1693 GGG40
SG Iron (Ductile Iron)	IS 1865 Gr 500/7	A536, 65-45-12	(0.7050)DIN1693 GGG50
Carbon steel			
Carbon steel (Wrought)	IS 1570 (part II) Gr. 40C8	ASTM A107 Gr. 1040	(1.1186)C40E/CK40
Carbon steel (Wrought)	IS 1570 (part II) Gr. 20C8	ASTM A107 Gr. 1020	(1.0402)C22
MS Steel	MS IS 2062 - Fe 410 W A	ASTM-A283 GR.D	DIN 1700 GR ST4-2 FABRICATED STEEL44
Cast Steel Grades			
Cast steel		ASTMA 216 Gr. WCB	1.0619(GS-C25)
Cast Stainless Steel			
Stainless Steel CF8M	IS 3444 Gr. 4	ASTMA 351 Gr. CF8M	1.4408(GX5CrNiMo19-11-2)
Stainless Steel CF8M	IS 3444 Gr. 4	ASTMA 743 Gr. CF8M	1.4408(GX5CrNiMo19-11-2)
Stainless Steel CF3M	IS 3444 Gr. 16	ASTMA 351 Gr. CF3M	1.4409(GX2CrNiMo19-11-2)
Stainless Steel CF3M	IS 3444 Gr. 16	ASTMA 743 Gr. CF3M	1.4409(GX2CrNiMo19-11-2)
Stainless Steel CF8	IS 3444 Gr. 1	ASTMA 351 Gr. CF8	1.4301(X5CrNi18-10)
Stainless Steel CF3	IS 3444 Gr. 15	ASTMA 351 Gr. CF3	1.4306(X2CrNi19 11)
Cast Chromium StainlessSteel			
Stainless Steel CA15	IS 3444 Gr. 10	ASTMA 217 Gr. CA15	1.4106&1.448(DIN17445 GX12Cr14)
Stainless Steel CA15	IS 3444 Gr. 10	ASTMA 743 Gr. CA15	1.4106&1.448(DIN17445 GX12Cr14)
Stainless Steel CA6NM	IS 3444 Gr. 24	ASTMA 487 Gr. CA6NM	1.4313&1.4317(GX5CrNiMo13-4)
Stainless Steel CA6NM	IS 3444 Gr. 24	ASTMA 743 Gr. CA6NM	1.4313&1.4317(GX5CrNiMo13-4)
Chromium StainlessSteel Round Bar Matterial			
Stainless steel 410	IS 1570 (part V) Gr. X12Cr12	ASTMA 276 type 410	1.4006(X10Cr13)
Stainless steel 420	IS 1570 (part V) Gr. X20Cr13	ASTMA 276 type 420	1.4021(X20Cr13)
Stainless steel 431	IS 1570 (part V) Gr. X15Cr16Ni2	ASTMA 276 type 431	1.4057(X20CrNi17)
Stainless steel 316	IS 1570 (part V) Gr. X04Cr17Ni12Mo2	ASTMA 276 type 316	1.4401(X5CrNiMo17122)
Stainless steel 316L	IS 1570 (part V) Gr. X02Cr17Ni12Mo2	ASTMA 276 type316L	1.4404(X2CrNiMo1810)
Cast Duplex Steel			
Duplex Steel 1A		ASTMA 890 Gr. CD4MCu	25Cr-5Ni-Mo-Cu
Duplex Steel 2A		ASTMA 890 Gr. CE8MN	24Cr-10Ni-Mo-N
Duplex Steel 3A		ASTMA 890 Gr. CD6MN	25Cr-5Ni-Mo-N
Super Duplex steel 4A		ASTMA 890 Gr. CD3MN	25Cr-7Ni-Mo-N
Super Duplex steel 5A		ASTMA 890 Gr. CE3MN	24Cr-10Ni-Mo-N
Non Ferious Materials			
Bronze	IS 318 Gr. LTB2 (CuSn5Zn5Pb5C)	ASTMB 584 - C90500	DIN 1705 Rg 5
Phosphor Bronze	IS 28 Gr. 1 (CuSn11PC)		
Zinc Free Bornze	IS 28 Gr. 1 (CuSn10C)		



1450-50Hz

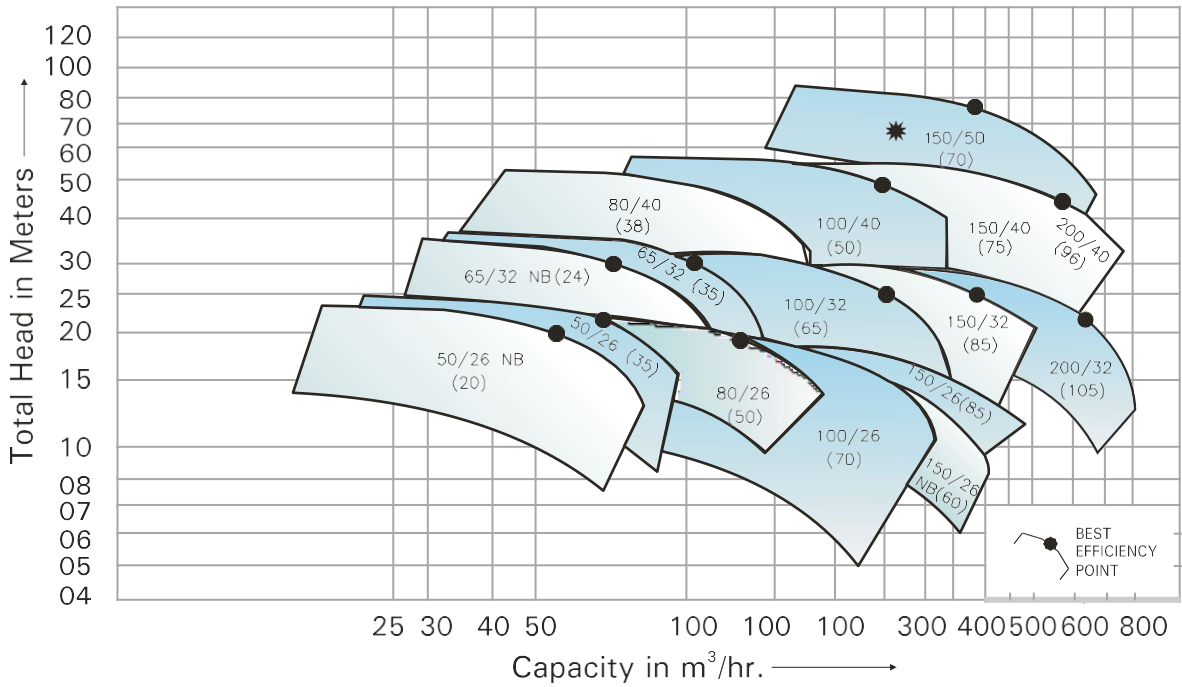

Note : Figures in bracket indicate maximum permissible solid size.

980RPM-50Hz

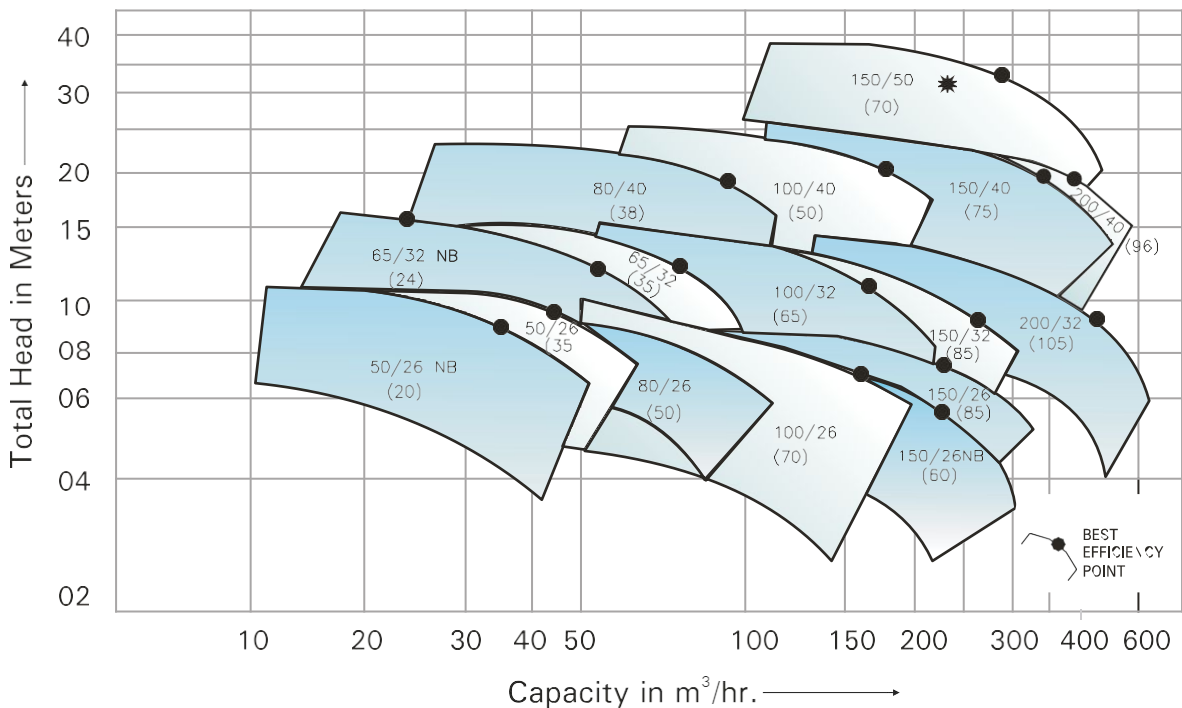

Note : Figures in bracket indicate maximum permissible solid size.

1150RPM-60Hz

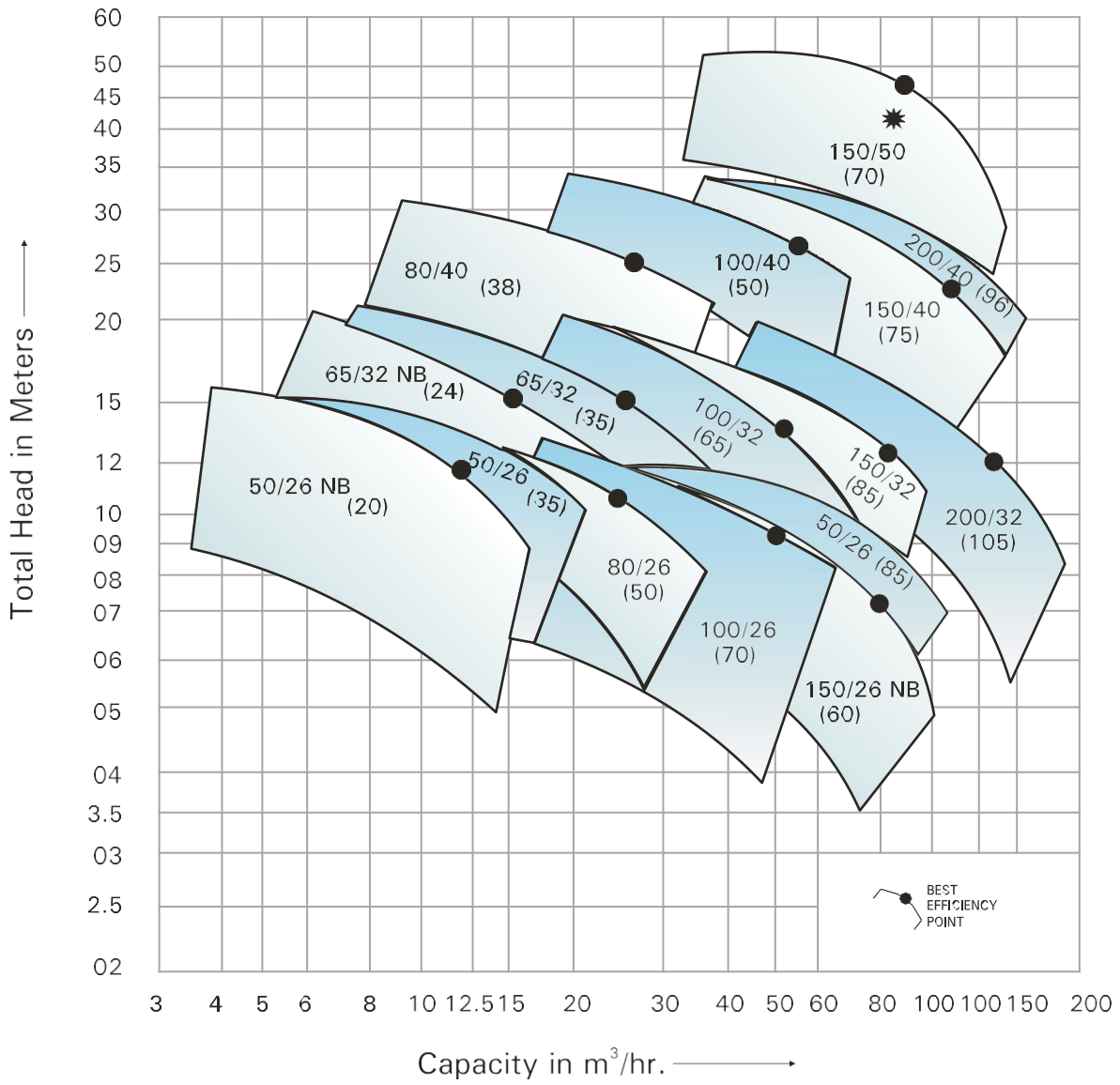

Note : Figures in bracket indicate maximum permissible solid size.



P K PUMPS PVT.LTD.

AN ISO 9001-2008 COMPANY



With best-in-class hydraulic performance coverage, unique design and advanced production capabilities, P.K. Pumps provides our customers with tailor-made pump solutions for process-critical applications. centrifugal pumps has made us a leading innovator in the processing , agriculture and Mining industry



P K PUMPS PVT.LTD.

AN ISO 9001-2008 COMPANY

Address: P.K.PUMPS AND PRECAST PVT LTD,
PLOT S40/1, BEHIND DIAMOND GRANITE, MIDC
KUPWAD, SANGLI, MAHARASHTRA, INDIA
Phone: +91-9422407840, +91-9175030202,
+91-9890151449
Email: pkpumps@rediffmail.com
Web: www.pkpumps.in

ISO 9001:2008

